

STJ-001 – Product Overview

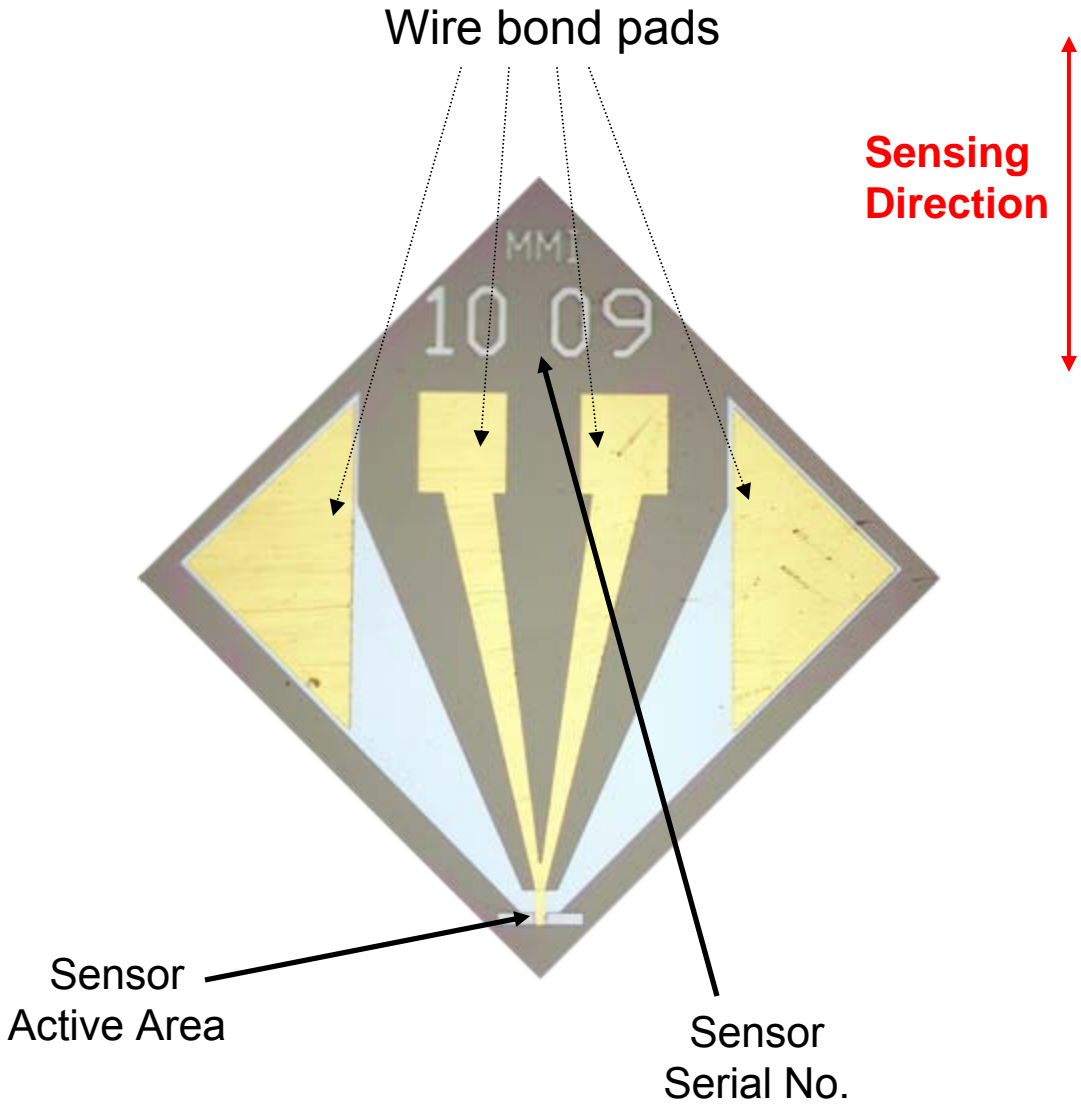

STJ-001 – Physical Dimensions

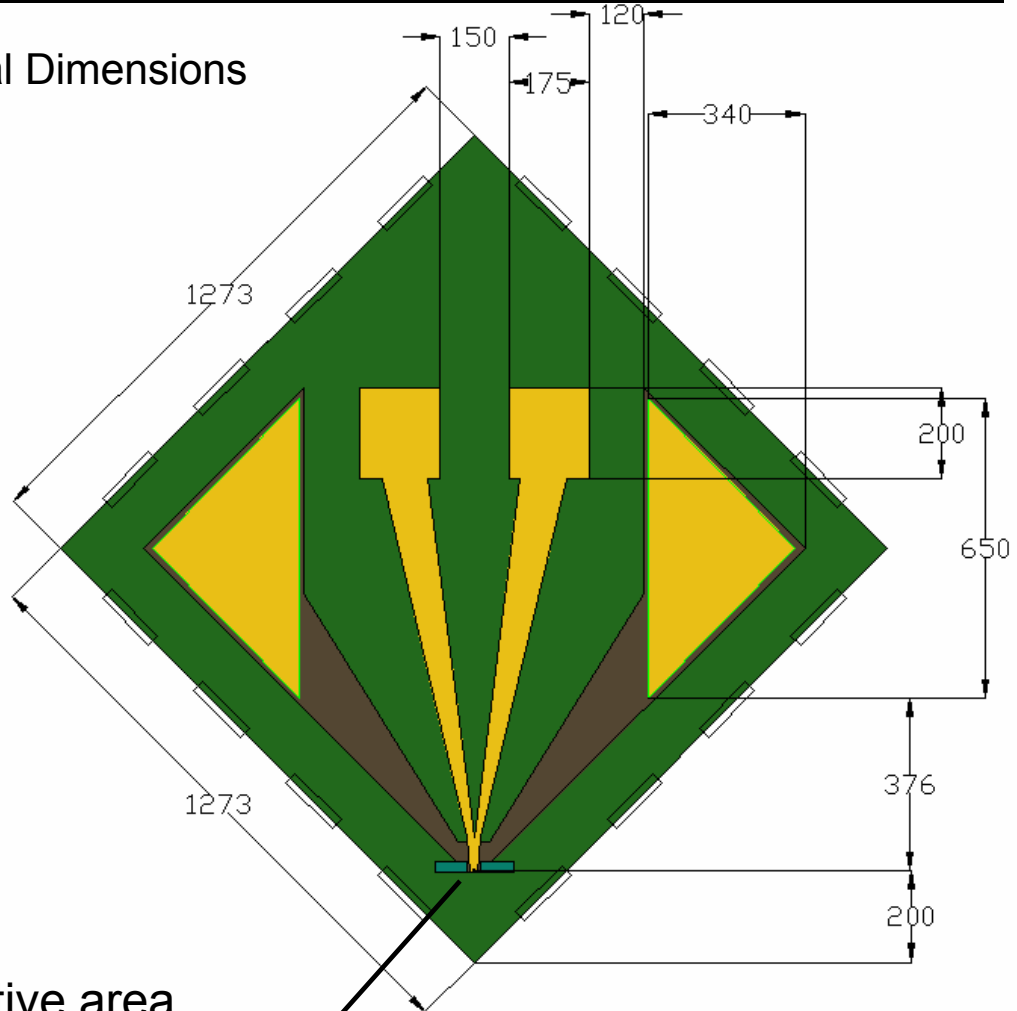

Sensor active area

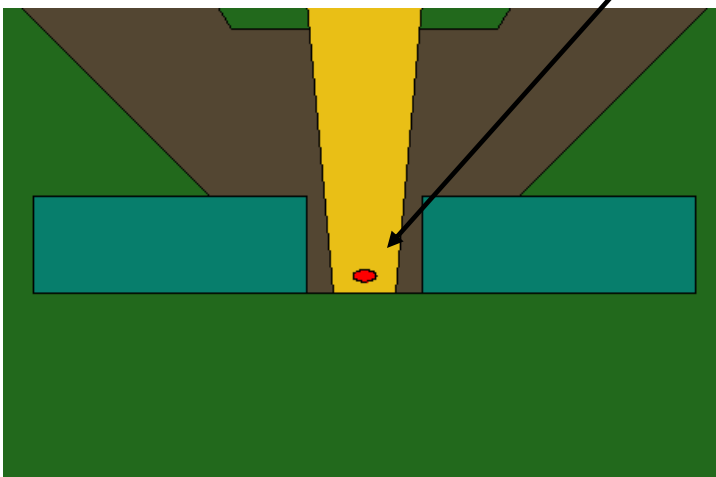

STJ-001 micro-sensor
Die thickness: 300 μm
Substrate: SiO₂ on Si
(Dimensions in μm)

Active Area: 4x2 μm
Active Area Shape: Ellipse
Active Thickness < 0.1 μm

STJ-001 – Effective Electrical Schematic

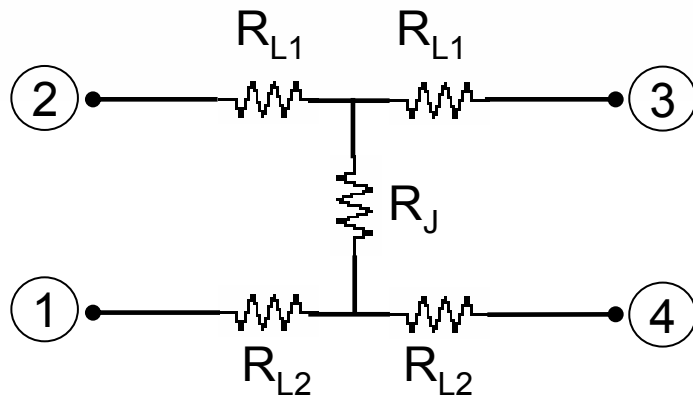
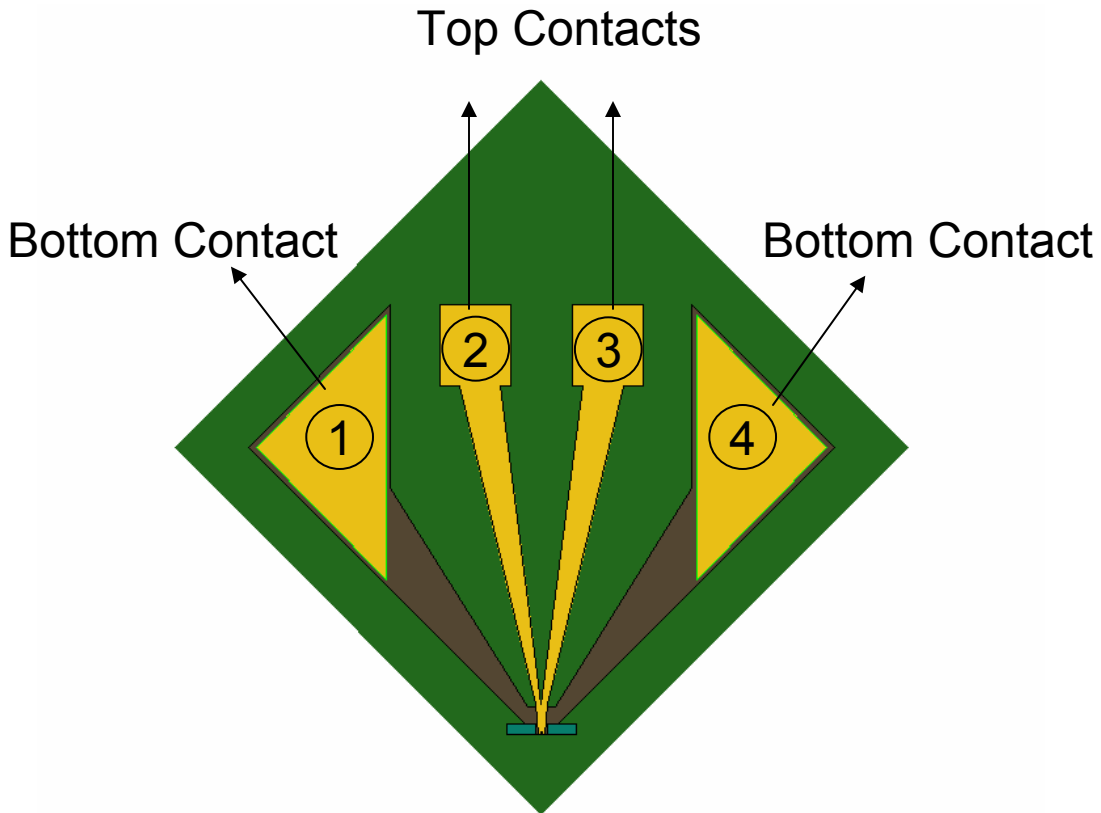

- R_J : Junction active resistance (SpinTJ sensor)
- R_{L1} : Top contact lead resistance (~5-10 Ω)
- R_{L2} : Bottom contact lead resistance (varies, 10-100 Ω)

Typical Sensor Connection Diagram (2-point)

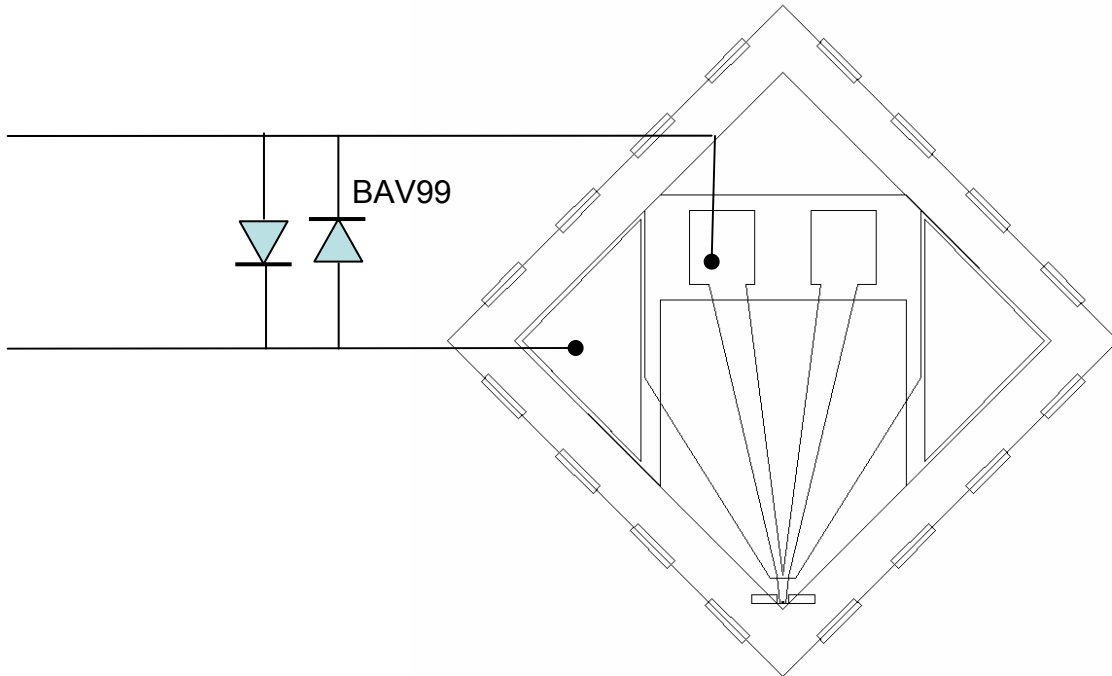

Notes:

1. Make sure to connect ESD-protection diodes (BAV99 or similar) as shown before the sensor is introduced into the circuit.
2. Make sure to voltage limit the supply used to power the sensor to below 0.2V.
3. A bridge can also be used for the purposes of null-detection.

STJ-001 – Specifications

PHYSICAL	Min.	Typical	Max.	Unit
Die Size		1.27 x 1.27		mm
Die Thickness	0.25	0.3		mm
Active Area Length		4.0		μm
Active Area Width		2.0		μm
Active Area Thickness		60	100	nm
Die Edge-to-Sensor Distance ¹	75	175	200	μm
ELECTRICAL				
Sensor Resistance ²	100	2000	50000	Ω
Lead Resistance ³	50	90	500	Ω
Recommended Operating Voltage	0.01	0.2	0.4	V
Maximum Operating Frequency ⁴	1	5	25	MHz
MAGNETIC				
Total 4-Point Magnetoresistance ⁵	40	80	200	%
Magnetic Field Sensitivity	0.5	0.8	1.5	%/G
Non-linearity ⁶ (+/- 1 G)		0.25	2.0	%
Hysteresis ⁷ (field range = +/- 1 G)		0.01	0.05	G
Non-linearity ⁶ (+/- 10 G)		0.50	5.0	%
Hysteresis ⁷ (field range = +/- 10 G)		0.5	2.0	G
Equivalent Field Noise (100 Hz)	50	90	250	nT/Hz ^{0.5}
Equivalent Field Noise (10 kHz)	5	10	25	nT/Hz ^{0.5}

STJ-001 – Specifications Notes

1. Sensor lapping offered by Micro Magnetics can bring this value to 5 μm . Contact Micro Magnetics for details.
2. Sensor resistances can be customized over a wide range of values (10 Ω -1 M Ω) . Please contact Micro Magnetics to discuss your specific needs.
3. Micro Magnetics' STJ series sensors are fabricated for four-point resistance measurements, but can also be used as two-terminal devices. The lead resistance is the additional resistance of electrical leads between the active area of the sensor and the sensor connector. The lead resistance will not have an adverse effect on sensor field noise, non-linearity, or hysteresis.
4. The sensor's operating frequency is limited by its RC time constant. The device's capacitance is nearly constant, but resistance values can vary quite a bit. Therefore, the operating frequency can vary a great deal with the sensor resistance (smaller resistance values allow higher operating frequencies).
5. Four-point magnetoresistance is measured over a field sweep range of 100-150 G.
6. Sensor non-linearity is defined as the percentage difference between the measured experimental transfer (resistance versus applied field) curve and the best-fit line to the data. For example, a transfer curve with a linear correlation coefficient of 0.995 would have a non-linearity of 0.5%. Contact Micro Magnetics for more details on how this figure is calculated.
7. Sensor hysteresis is defined as the average (magnetic field) absolute separation between the increasing and decreasing transfer curve data, over the field range of interest. Contact Micro Magnetics for more details on how this figure is calculated.

STJ-001 – Notes and Handling Instructions

1. The active area of the sensor element is 2x4 microns in size. The sensor active area is located near the bottom corner of the die. **Avoid physical contact with the die end of the package.**
2. The active part of the sensor can be accessed via 2-probe or 4-probe measurement. For a two-probe measurement, wire bonds should be made to one top contact (2,3) and one bottom contact (1,4). For 4-probe measurements, one top and one bottom contact should be used for the current (I) leads and one top and one bottom contact should be used for the voltage (V) leads. **Note that measuring resistance between pads 1 to 4 or pads 2 to 3 will bypass the sensor and will not permit a magnetic field measurement.**
3. Please store sensors as they were shipped and in a location which is away from sources of radiated electromagnetic fields (ESD/EMI).
4. Sensors are sensitive to electrostatic discharge (ESD). Be careful to ground tools and your hands when handling the sensors. If possible, be sure to wear grounding straps when handling the sensors.
5. SpinTJ sensors will fail if subjected to a sufficiently large differential voltage. A good rule-of thumb is to **limit the voltage drop across the sensor element to 200 mV** or less at all times. The currents and voltages applied by most resistance measurement devices are sufficient to destroy the SpinTJ sensor. **Do not test sensors with a standard ohmmeter.**
6. To directly measure SpinTJ sensor resistance, connect to a constant current source, and measure the voltage drop directly across the device. In order to limit the voltage drop across the SpinTJ sensor, initial applied current values should NOT exceed 10 μ A. If this amount of current is not sufficient to measure the device resistance, the current may be increased gradually until the differential sensor voltage is ~100-200 mV.

STJ-001 – Detailed Description and Notes

The STJ-001 is a bipolar, linear-output magnetic microsensor which works on a magnetoresistive principle. Over the specified range of operation, the resistance of this device is approximated by

$$R(H) = R_0(1 + SH)$$

where R_0 is the sensor resistance at zero field, H is the magnetic field strength in gauss (G) in the sensing direction (indicated on page 1), and S is the sensor's coefficient of sensitivity, expressed in units of 1/G. The value of S is provided in the datasheet which is sent with each sensor probe. Note that the value of R_0 can change by up to 25% if the sensor is exposed to large DC magnetic fields. However, this should not greatly affect the field-dependent part of the sensor response.

The active area of the sensor is an elliptical film 4-9 microns long, 2-3 microns wide, and 5-20 nanometers thick. This film is located on the top surface of the sensor die, a distance of 75-150 microns from the bottom point of the sensor die, as shown on page 1. Optional polishing can be done to bring this distance to ~3-5 microns.

Making a measurement of field can be accomplished by any method which allows precise measurement of the sensor's electrical resistance, with the following requirement: The sensor has a safe operating differential voltage of no larger than 0.5 V. **Under no circumstances the sensor to be subjected to differential voltages of more than 0.5 V in either direction.** While the sensor has on-board protection to avoid damage caused by larger voltages, the STJ-001 remains an electrically sensitive device. **Even using a standard multimeter to measure the resistance of the STJ-001 can apply hazardous voltage levels to the sensor.**

STJ-001 – Detailed Description and Notes (2)

The simplest way to use the STJ-001 sensor is to apply a constant current across two terminals of the device, and measure the corresponding voltage. Alternatively, a constant voltage can be supplied and the current measured to read the sensor resistance.

Another way to use the STJ-001, if the above methods are not feasible, is to build a simple voltage divider with the STJ-001 and a fixed resistor in series. Applying a known voltage to the two-resistor circuit and measuring the voltage across the STJ-001 (or across the fixed resistor) will allow for calculation of the resistance of the STJ-001, and therefore the magnetic field.

Testing the STJ-001 Sensor:

In general, every sensor which is operating properly should behave in the following ways:

1. The resistance of the STJ-001 in small magnetic fields should be within ~25% of the calibrated resistance (this is available on an included datasheet or by contacting Micro Magnetics). Almost always, a sensor which has been damaged has a zero-field resistance which is either infinite (open circuit) or much smaller than the quoted R_0 .
2. A marked change in the resistance of the STJ-001 should be observed when a small magnet (i.e. a refrigerator magnet or even a magnetized tool) is brought to within 1" of the sensor's active area.

If you are unsure about the condition of an STJ-001 sensor, the above tests are a good first step to take.

Technical Support:

If you require technical support please contact Micro Magnetics: support@micromagnetics.com or (508) 672-4665.